

THIS DRAWING IS UNPUBLISHED. RELEASED FOR PUBLICATION
 © COPYRIGHT - ALL RIGHTS RESERVED.

LOC	DIST	REVISIONS				
P	LTR	DESCRIPTION	DATE	DWN	APVD	
ES	00	B1	UPDATED ECR-14-004955	22JUL2014	T.Q W.H	

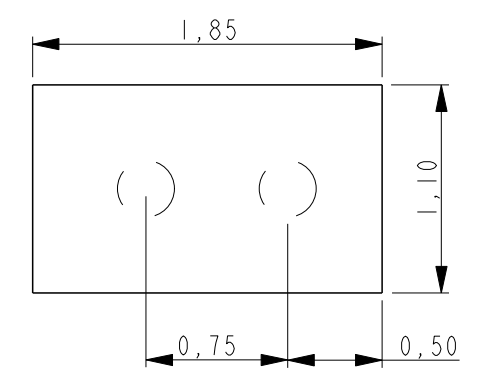
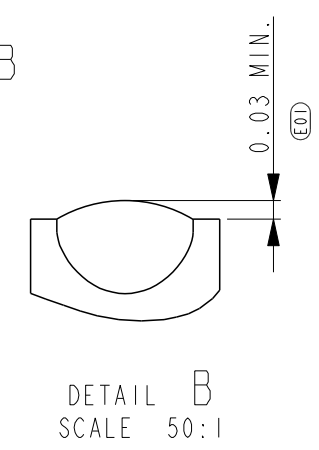
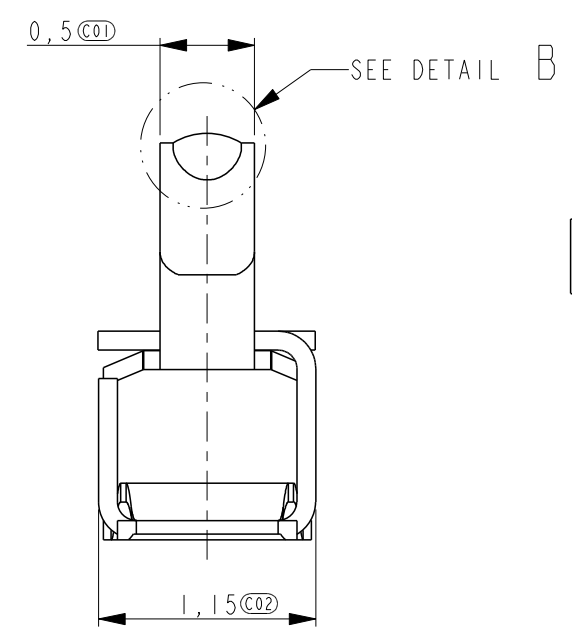
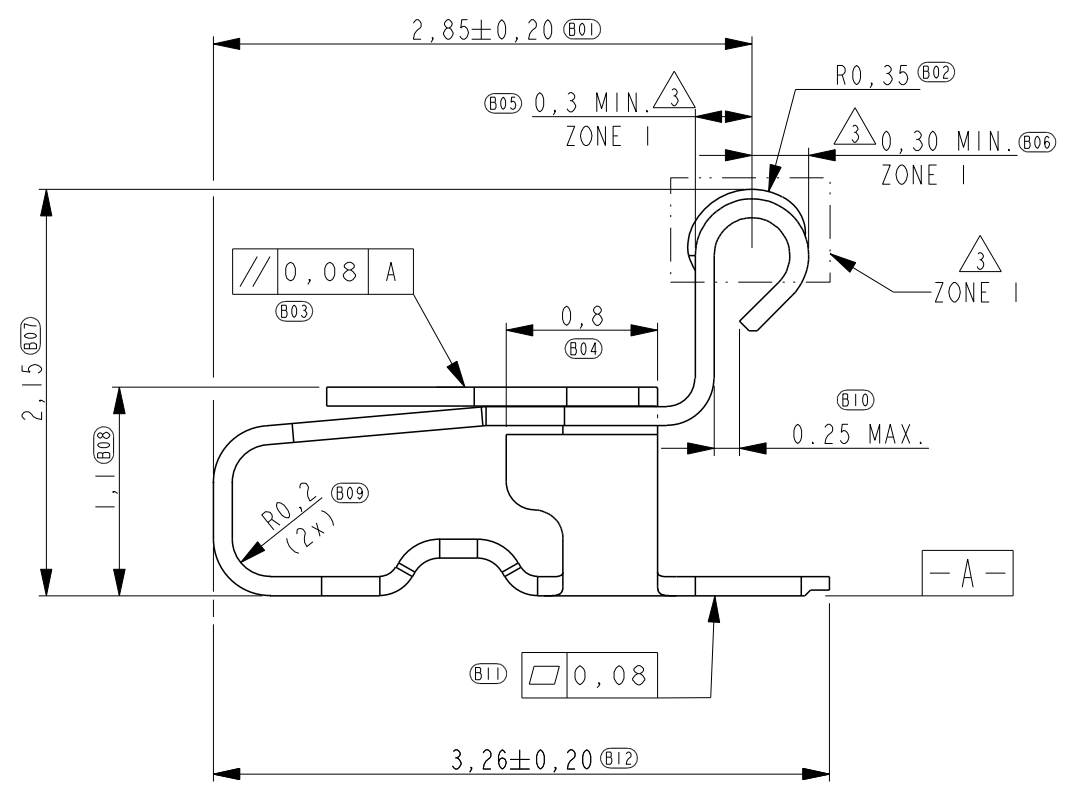
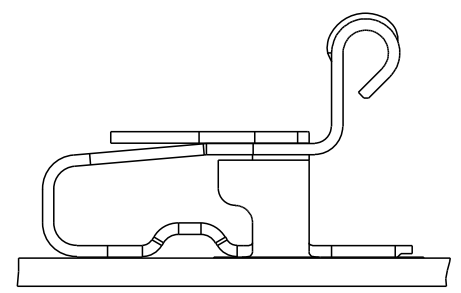
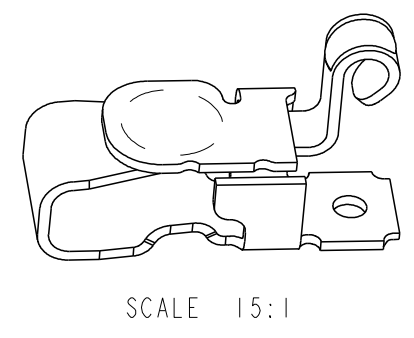
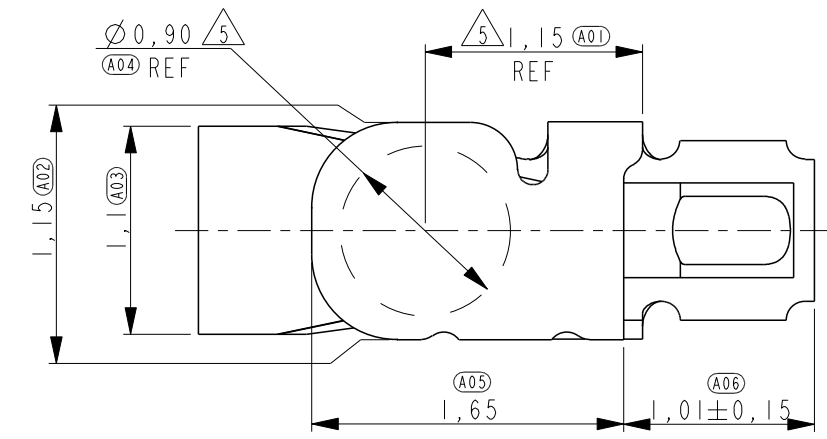

RECOMMENDED PWB LAY-OUT (±0.05)
 DASHED CIRCLES ARE THE LOCATION OF THE SPRING FINGER BOTTOM HOLES

- 1 PART NUMBER: 1551573-5 AS SHOWN.
- 2 MATERIAL: STAINLESS STEEL.
- 3 PLATING: 1,3um MIN. NICKEL UNDERLAYER ALL OVER
 ZONE 1: 0,50um MIN. GOLD
 ZONE 2: 0,05-0,3um GOLD FLASH
- 4 NORMAL FORCE 0.6±0.2N AT NOMINAL HEIGHT 1.6MM.
- 5 INDICATED SURFACE TO BE USED AS PICK AND PLACE SURFACE.

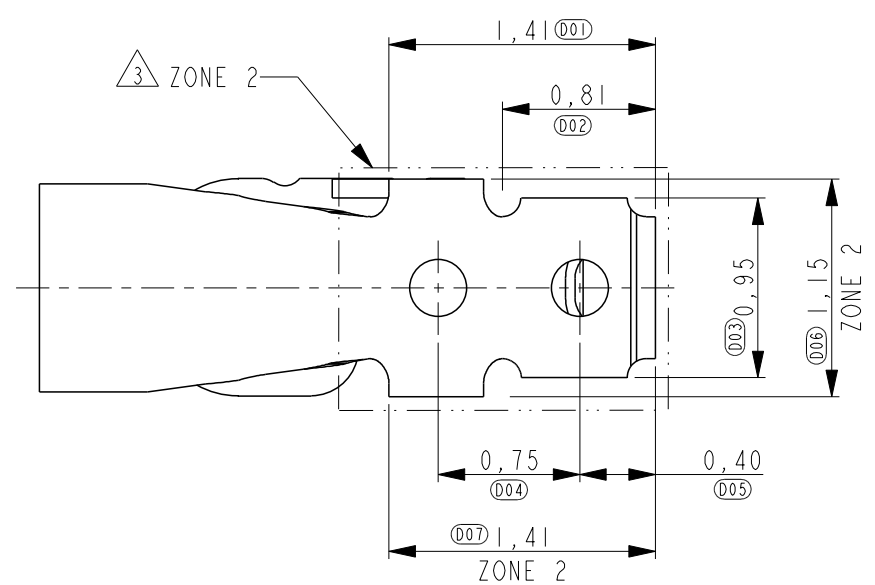

THIS DRAWING IS A CONTROLLED DOCUMENT.		DWN 13 JUN 2010 Tony Zhang	TE Connectivity		
DIMENSIONS: mm		CHK 13 JUN 2010 Martin Li			
TOLERANCES UNLESS OTHERWISE SPECIFIED:		APVD 13 JUN 2010 Steven Yao	NAME SPRING FINGER H=2,15		
0 PLC ±0.2 1 PLC ±0.1 2 PLC ±0.1 3 PLC ±0.05 4 PLC ANGLES ±°		PRODUCT SPEC 108-115008	APPLICATION SPEC -		
MATERIAL 2		FINISH 3	SIZE A3	CAGE CODE C-1551573	RESTRICTED TO -
CUSTOMER DRAWING			SCALE 25:1	SHEET 1 OF 2	REV B1

THIS DRAWING IS UNPUBLISHED.

RELEASED FOR PUBLICATION

© COPYRIGHT -

ALL RIGHTS RESERVED.

LOC ES DIST 00

REVISIONS

P	LTR	DESCRIPTION	DATE	DWN	APVD
-	-	SEE SHEET 1	-	-	-

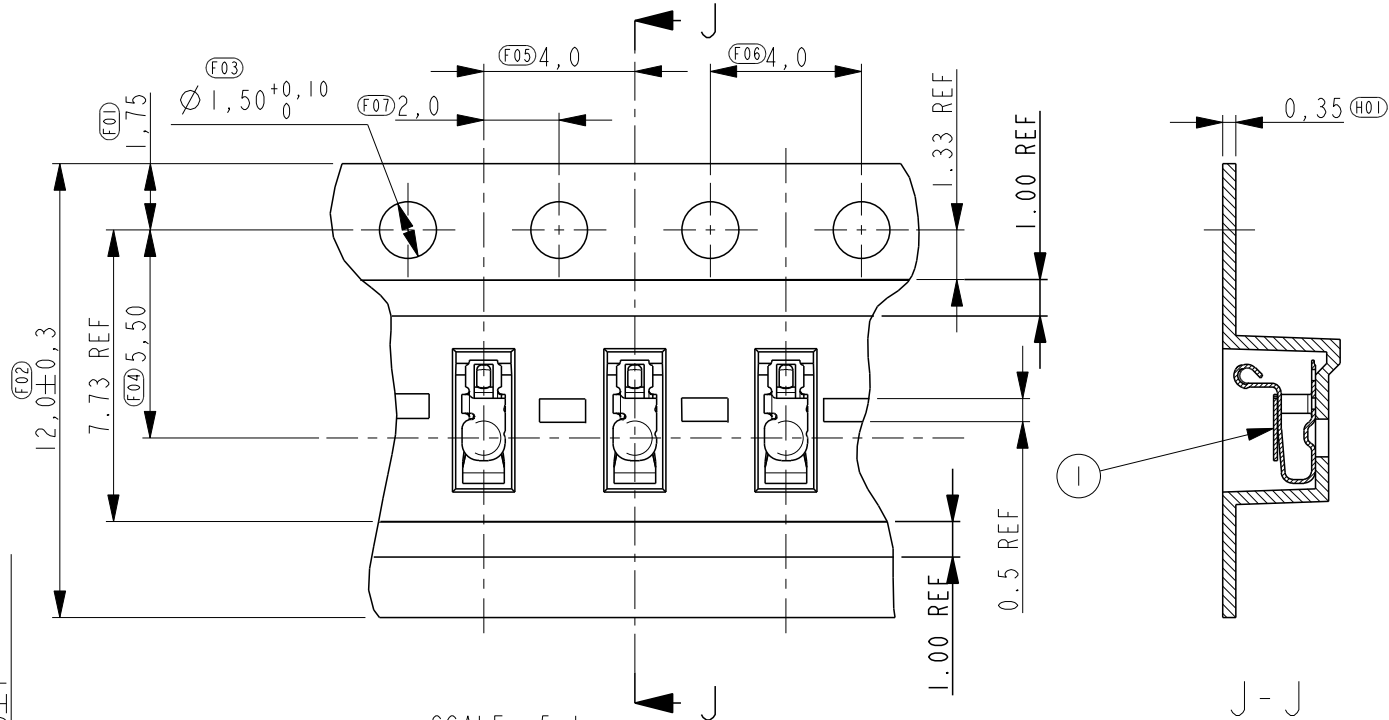

SCALE 5:1

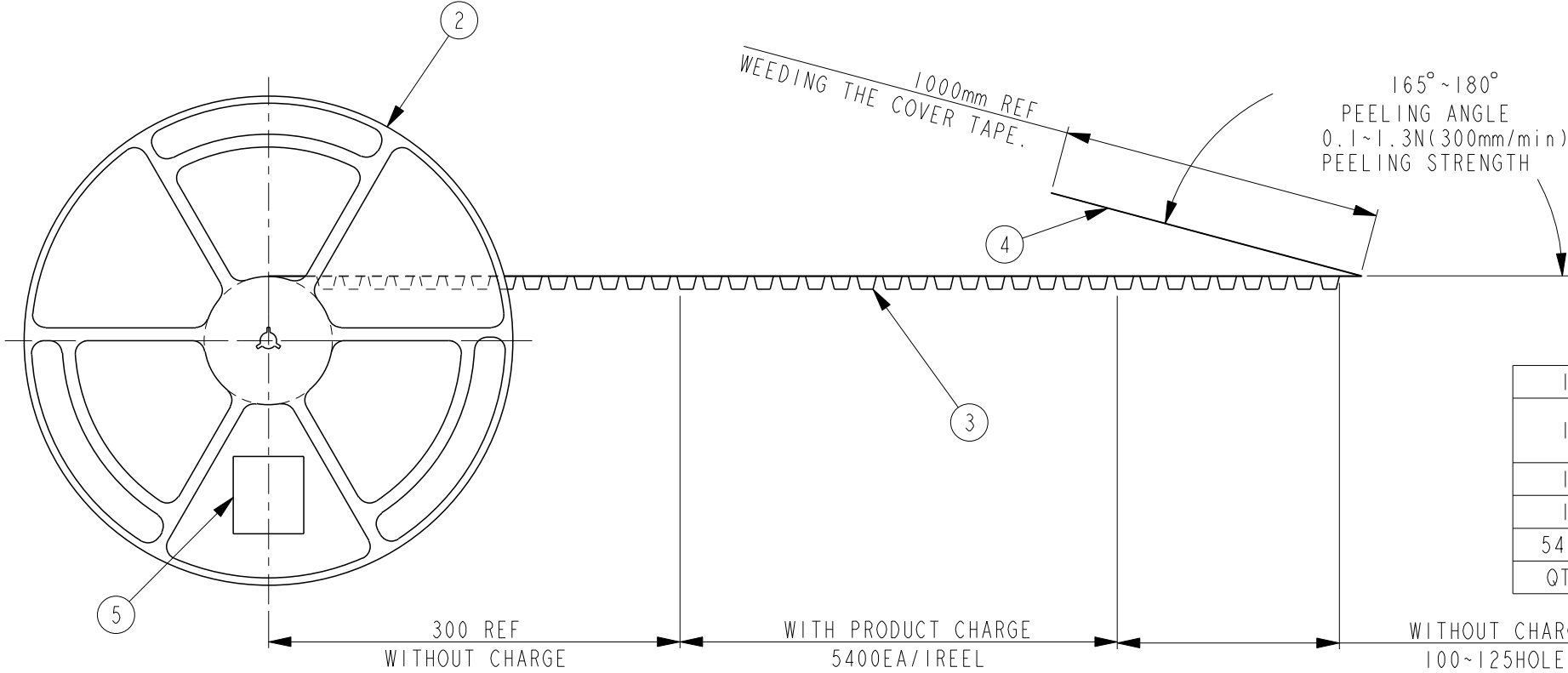
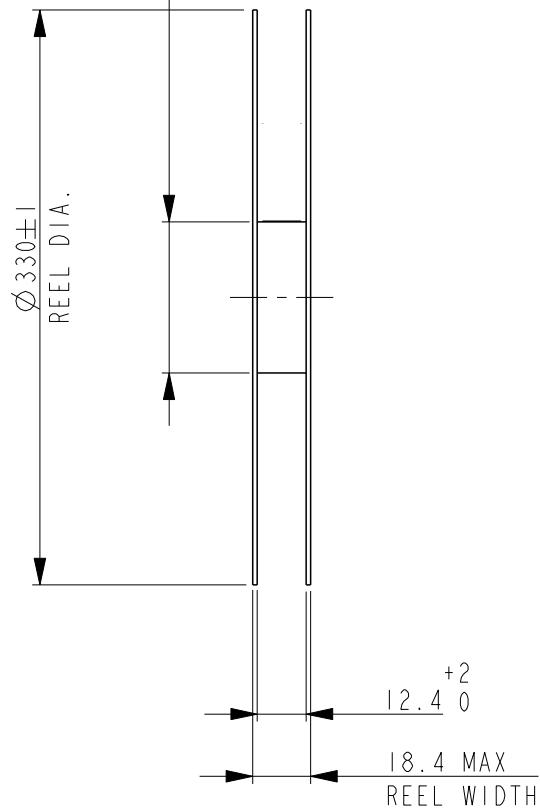

1	LABEL	5
1	COVER TAPE (HEAT SEALING)	4
1	EMBOSS	3
1	PLASTIC REEL	2
5400	SPRING FINGER	1
QTY	DESCRIPTION	ITEM

THIS DRAWING IS A CONTROLLED DOCUMENT.

DIMENSIONS:	TOLERANCES UNLESS OTHERWISE SPECIFIED:
mm	
	0 PLC ±0.2
	1 PLC ±0.1
	2 PLC ±0.1
	3 PLC ±0.05
	4 PLC ±
	ANGLES ±5°
MATERIAL	FINISH

DWN
CHK
APVD
PRODUCT SPEC
APPLICATION SPEC
WEIGHT
CUSTOMER DRAWING

STE TE Connectivity

NAME			
SPRING FINGER H=2,15			
SIZE	CAGE CODE	DRAWING NO	RESTRICTED TO
A3		C-1551573	-
SCALE 5:1		SHEET 2 OF 2	REV B1